

GARMIN GWX-68/70 WEATHER RADAR SYSTEM - MAINTENANCE PRACTICES

1. General

- A. This section gives maintenance practices for the Garmin GWX-68/70 Weather Radar System. The GWX-68/70 is the only component of the weather radar system included in this section. For a general description of the GWX-68/70 weather radar, refer to Garmin GWX-68/70 Weather Radar - Description and Operation.

2. GWX-68 Weather Radar Removal/Installation

- A. Remove the GWX-68 Weather Radar (Refer to Figure 201).

- (1) Remove electrical power from the airplane.
 - (a) Disengage the RADAR R/T circuit breaker on the avionics circuit breaker panel.
- (2) Remove the radome to get access to the weather radar.
- (3) Disconnect the electrical connector from the weather radar.
- (4) If the bonding straps are attached to the top side of the radar assembly, remove the screws and washers that attach the bonding straps to the radar assembly.
- (5) When you do the steps that follow record the quantity of washers at each of the four attachment bolts.
- (6) If the bonding straps are attached to the bottom two attach bolts, remove the bottom bolts and washers from the radar assembly.
- (7) Carefully hold the weather radar and remove the remaining bolts and washers that attach the weather radar assembly to the bulkhead assembly.
- (8) Remove the weather radar from the bulkhead assembly.

- B. Install the GWX-68 Weather Radar (Refer to Figure 201).

NOTE: To prevent water from entering the radome, inspect the seal between the radome and the radar pod for condition.

- (1) Put the weather radar in position on the bulkhead assembly.
- (2) When you do the steps that follow make sure you install the correct recorded quantity of washers at each of the four attachment bolts.
- (3) Install the top bolts and washers to hold the weather radar in position on the bulkhead assembly.
- (4) If the bonding straps were attached to the bottom two attach bolts, install the bonding straps and the bottom bolts and washers on the radar assembly.
- (5) If the bonding straps were attached to the top side of the radar assembly, install the screws and washers that attach the bonding straps to the radar assembly.
- (6) Make sure that the weather radar is Type I electrically bonded to the bulkhead assembly. Refer to Chapter 20, Electrical Bonding - Maintenance Practices.
- (7) Connect the electrical connector to the weather radar.
- (8) Engage the RADAR R/T circuit breaker on the copilot's circuit breaker panel.
- (9) Make sure that the radome seal is in good condition and intact. Replace the seal if necessary. Refer to Radome Seal Removal/Installation.
- (10) Install the radome.

- C. GWX-68 Weather Radar Post-Maintenance Checks

- (1) Do the GWX-68 weather radar software and configuration load. Refer to Garmin G1000 Line Maintenance Manual, Supplier Publication List.
- (2) Do the Weather Radar Test. Refer to, Garmin GWX-68/70 Weather Radar - Adjustment/Test.

3. GWX-70 Weather Radar Removal/Installation

- A. Remove the GWX-70 weather radar, (refer to Figure 202).

- (1) Remove electrical power from the airplane.
 - (a) Disengage the RADAR R/T circuit breaker on the avionics circuit breaker panel.
- (2) Remove the radome to get access to the weather radar.
- (3) If necessary, remove GWX-70 weather antenna from radar. Refer to the steps for: Remove the GWX-70 weather

antenna from the mounting plate.

- (4) Disconnect the electrical connector from the weather radar.
- (5) If the bonding straps are attached to the top side of the radar assembly, remove the screws and washers that attach the bonding straps to the radar assembly.
- (6) When you do the steps that follow, record the quantity of washers at each of the four attachment bolts.
- (7) If the bonding straps are attached to the bottom two attach bolts, remove the bottom bolts and washers from the radar assembly.
- (8) Carefully hold the weather radar and remove the remaining bolts and washers that attach the weather radar assembly to the bulkhead assembly.
- (9) Remove the weather radar from the bulkhead assembly.

B. Install the GWX-70 weather radar

NOTE: To prevent water from entering the radome, inspect the seal between the radome and the radar pod for condition.

- (1) Put the weather radar in position on the bulkhead assembly.
- (2) When you do the steps that follow make sure you install the correct recorded quantity of washers at each of the four attachment bolts.
- (3) Hold the radar assembly in position against the bulkhead assembly.
- (4) Install the top bolts and washers to hold the weather radar in position on the bulkhead assembly.
- (5) If the bonding straps were attached to the bottom two attach bolts, install the bonding straps and the bottom bolts and washers on the radar assembly.
- (6) If the bonding straps were attached to the top side of the radar assembly, install the screws and washers that attach the bonding straps to the radar assembly.
- (7) Make sure that the weather radar is Type I electrically bonded to the bulkhead assembly. Refer to Chapter 20, Electrical Bonding - Maintenance Practices.
- (8) If necessary, install the GWX-70 weather antenna on the mounting plate. Refer to the steps for: Install the GWX-70 weather antenna to the mounting plate.
- (9) Connect the electrical connector to the weather radar.
- (10) Engage the RADAR R/T circuit breaker on the avionics circuit breaker panel.
- (11) Make sure that the radome seal is in good condition and intact. Replace the seal if necessary. Refer to Radome Seal Removal/Installation.
- (12) Install the radome.

C. GWX-70 Weather Radar Post Maintenance Checks

- (1) Do the GWX-70 weather radar software and configuration load. Refer to Garmin G1000 Line Maintenance Manual, Supplier Publication List.
- (2) Do the Weather Radar Test. Refer to, Garmin GWX-68/70 Weather Radar - Adjustment/Test.

4. GWX-70 Weather Antenna Removal/Installation

A. Remove the GWX-70 weather antenna from the mounting plate.

- (1) Remove electrical power from the airplane.
 - (a) Disengage the RADAR R/T circuit breaker on the avionics circuit breaker panel.
- (2) Remove the radome to get access to the weather radar.
- (3) Carefully hold the weather antenna and remove the screws that attach it to the mounting plate on the weather radar.
 - (a) Remove the weather antenna from the airplane.

B. Install the GWX-70 weather antenna to the mounting plate.

- (1) Put the weather antenna in its position on the mounting plate on the weather radar.
 - (a) Install the screws.
 - (b) Torque the screws to 25 inch pounds, +1 or -1 inch pound.
- (2) Make sure that the weather radar is Type I electrically bonded to the bulkhead assembly. Refer to Chapter 20,

Electrical Bonding - Maintenance Practices.

- (3) Make sure gasket is installed over pins before connecting radar connector.
- (4) Connect the electrical connector to the weather radar.
- (5) Engage the RADAR R/T circuit breaker on the avionics circuit breaker panel.
- (6) Make sure that the radome seal is in good condition and intact. Replace the seal if necessary. Refer to, Radome Seal Removal/Installation.
- (7) Install the radome.

C. GWX-70 Weather Antenna Post-Maintenance Checks

- (1) Do the GWX-70 Weather Radar software and configuration load. Refer to the Garmin Line Maintenance Manual, Supplier Publication List.

5. Radome Seal Removal/installation

A. Remove the Radome Seal (Refer to Figure 203).

- (1) Remove the radome from the pod assembly.
- (2) Clean the existing sealant from the pod assembly. Refer to Chapter 20, Fuel, Weather, Pressure and High Temperature Sealing - Maintenance Practices.

B. Install the Radome Seal (Refer to Figure 203).

- (1) Carefully slide the radome assembly onto the pod assembly and attach with the screws.
- (2) Using a suitable marker, draw a line around the pod assembly at the aft edge of the radome.
- (3) Remove the radome from the pod and mark another line 0.25 inch (6.35 mm) forward of the first line marked previously.
- (4) Clean the area marked for sealant installation with MPK or equivalent.
- (5) Apply a bead of Type I, Class B sealant to the cleaned area on the pod as shown. Refer to Chapter 20, Fuel, Weather, Pressure and High Temperature Sealing - Maintenance Practices.
- (6) Apply a thin coat of petrolatum or equivalent on the inside and outside of the aft end of the radome assembly as a parting agent.
- (7) Carefully slide the radome assembly onto the pod assembly only to the point where the attaching screws can be installed. Install the screws.
- (8) Using a wooden scraper or other tool, remove the excess sealant leaving the top of the sealant level with the surface of the pod assembly.
- (9) Allow the sealant to fully cure. Refer to Chapter 20, Fuel, Weather, Pressure and High Temperature Sealing - Maintenance Practices.
- (10) Remove the attaching screws and make sure that the radome can be removed without disturbing the sealant.

NOTE: If the radome cannot be removed or reinstalled without disturbing the sealant, repeat the steps above.

- (11) Carefully slide the radome assembly onto the pod assembly and attach with the screws.
- (12) Sealant may be painted to match existing paint on pod assembly if desired.

Figure 201 : Sheet 1 : GWX-68 Weather Radar Installation

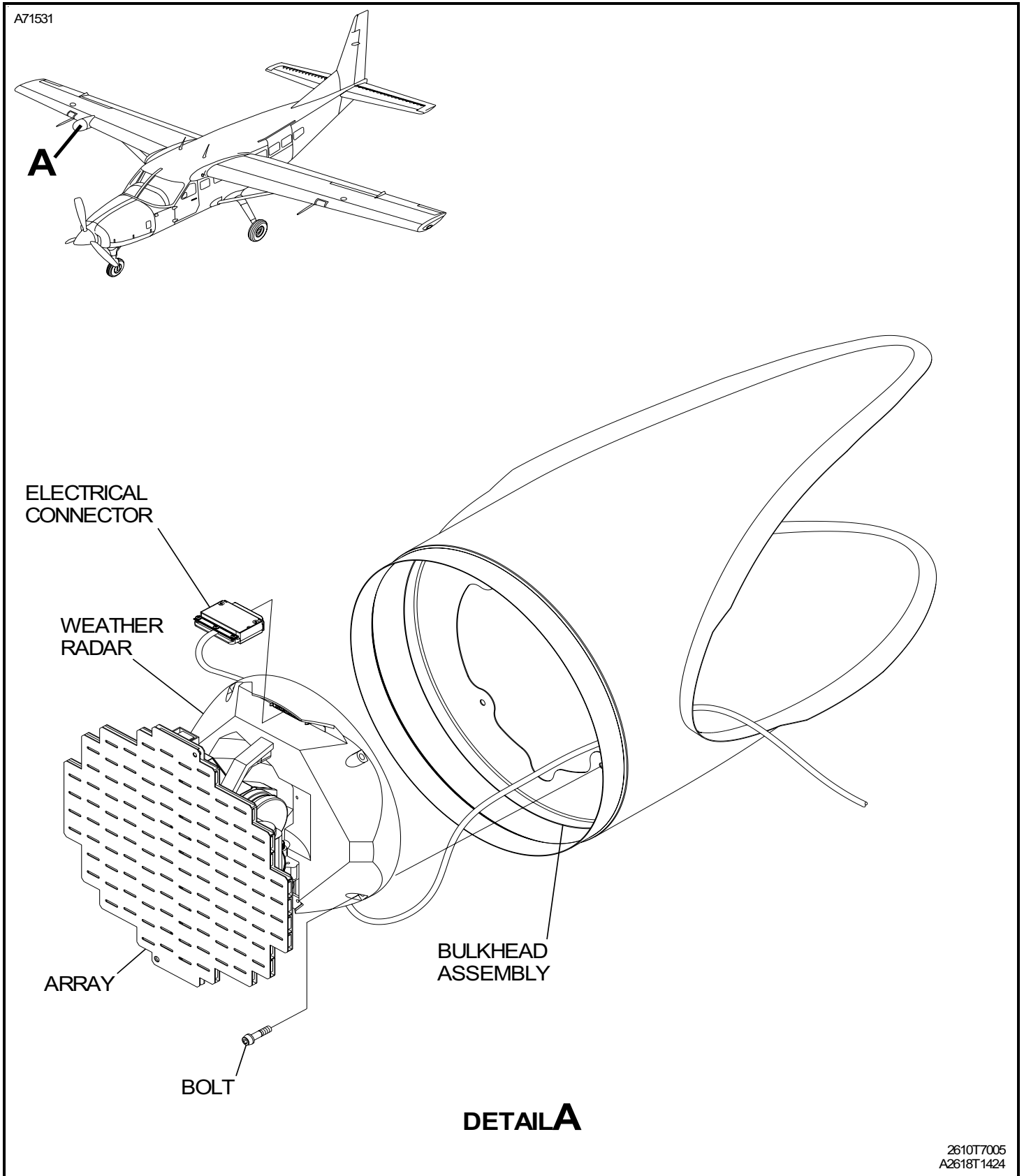

Figure 202 : Sheet 1 : GWX 70 Weather Radar Installation (10")

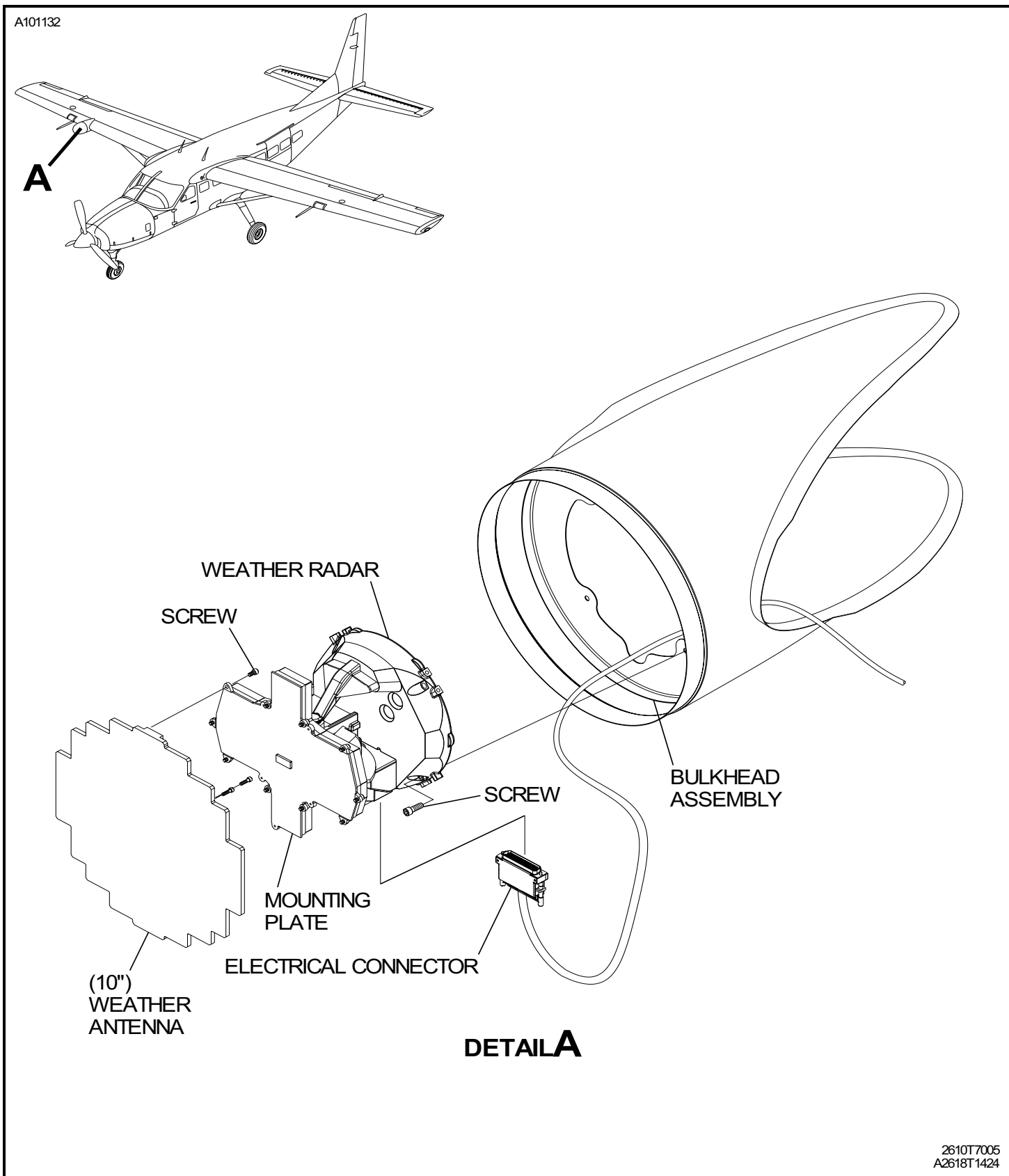

Figure 203 : Sheet 1 : Radome Seal Installation

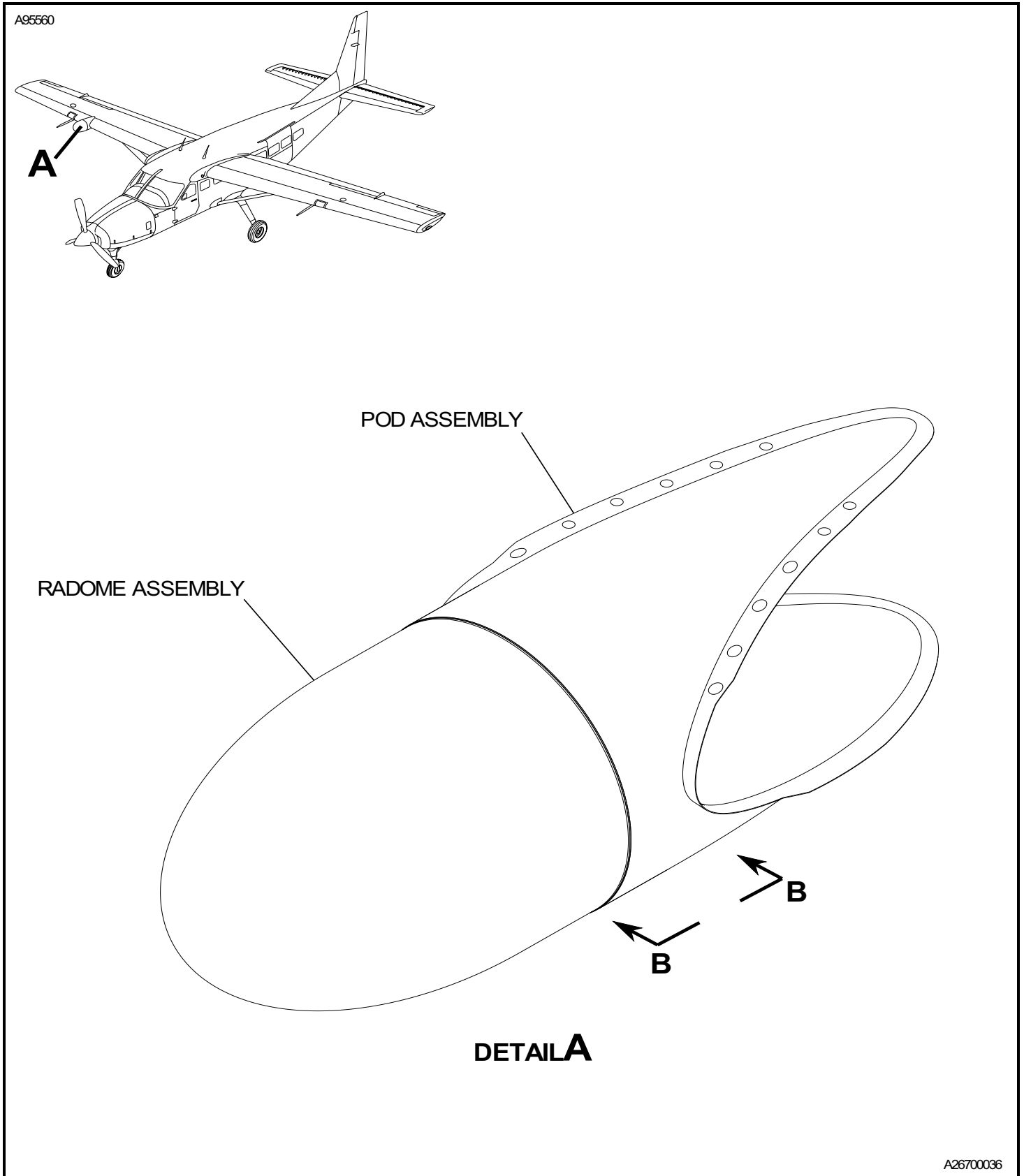

Figure 203 : Sheet 2 : Radome Seal Installation

